

Turnstile ID Gate 1900 Wheelchair



Description

The **ID GATE 1900 Wheelchair** is a full-height turnstile with a wheelchair gate for barrier-free access, providing high security and a convenient access solution for people with disabilities.

The ID GATE 1900 Wheelchair is also used in stadiums to control access to spectator or VIP areas. Overall, the ID GATE 1900 is a reliable access control solution that contributes to enhancing the security and comfort of visitors.

HIGHLIGHTS

- Durability, high operational reliability and fast response
- One-sided or two-sided operation
- Automatic reset function (The turnstile is automatically locked within 5 seconds when the passenger delays the entry)
- Automatic anti-panic function that guarantees free passage in emergency situations (e.g. power failure or fire alarm)
- Built-in LED indicators for continuity clearance
- 3 year warranty



Manual control of entry direction



2300mm tall interior



304S Stainless steel



120° Rotor Standard (three sections)



Anti-tailgating function: Allows only one person to pass at a time

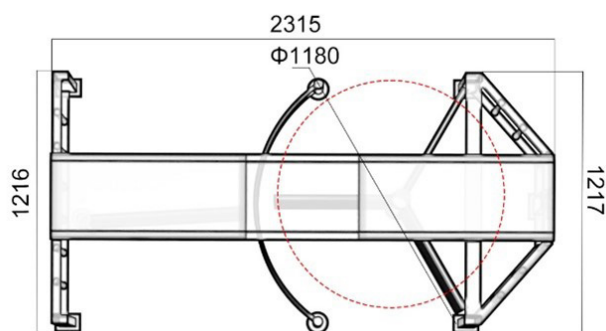
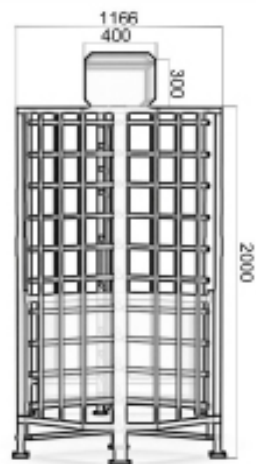
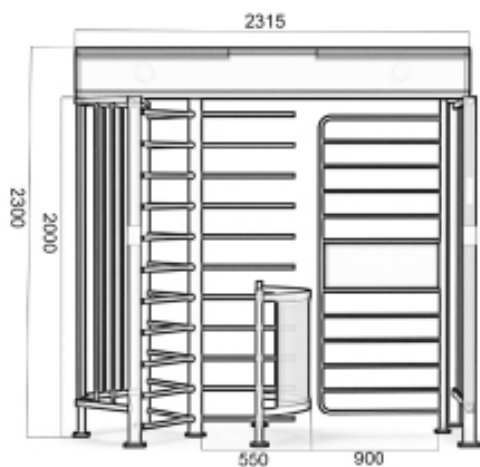

TECHNICAL DATA

Specification	
Dimension	2315 x 1217 x 2300mm (L x W x H)
Passage width	2 passages, 550 mm/passage (for pedestrians), 900mm passage (accessible/barrier-free)
Direction of passage	One-sided or two-sided passage possible
Material	Stainless steel (304)
Power supply	AC220V/110V, 50/60Hz
Power consumption	40W
Operating voltage	24V DC
Flow Rate	35-40 people per minute
Emergency mechanism	Automatic opening of the turnstile
Communication interface	RS485, Dry contact, Relay signal
Net weight	380kg/piece
Operating temperature	- 15 °C up to 60 °C
Optional	<ul style="list-style-type: none"> • RFID reader (Mifare / EM / Hitag) • Barcode / QR Code reader • Combined QR Code / RFID reader • Remote control (wired / wireless) • Third-party reader installation upon request